

LAS 300 MDHD TkHA9

Technical Documentation

Date of issue: 08 / 2010



ULT 300

Modular system

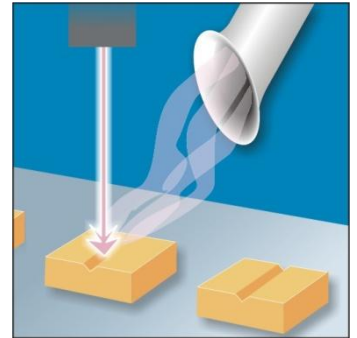

**clean air,
strong performance**

**LAS-series,
modular air
extraction and
filtration units for
laser smoke**



Air handling equipment for environmental and health protection

Technical documentation

Air extraction and filtration unit

LAS 300 MDHD TkHA9



Use and application

The **LAS300** is suitable for collecting and filtering dry and non-combustible types of dust contained in non-explosive air mixtures produced during laser machining. Any emitted and partially unhealthy **types of dust** ought to be extracted by collecting elements directly at their place of origin and be filtered by the **LAS300**. The material of the filter element ensures effective filtering out of the various dust particle sizes. The combination of main module and secondary module guarantees a separation efficiency of > 99% by multiple cleaning, provided the filter elements are exchanged regularly.



laser smoke

Examples

- ⇒ laser cutting
- ⇒ laser engraving
- ⇒ laser structuring

ULT 300 modular air extraction and filtration unit

mobile unit,
with vacuum and filter modules and storage filter system
robust steel housing, powder coated

- filter module RAL 7035, silver grey
- vacuum generator module RAL 7001, light grey

Filter system:

storage filter system, filters which are replaced once they are saturated.

Filter technical:

main filter module HFM050

(1) pocket pre-filter in a disposal carton

filter class F9 fine dust filter, according to DIN 779

(2) pre filter mats

filter class F5 fine dust filter, according to DIN EN 779

(3) HEPA filter H13

filter class H13 HEPA filter, according to DIN EN 1822

secondary filter module HFM021

(1) adsorption filter

filter medium activated charcoal, 10 kgs

Components:

Air flow controller

stepless adjustment for the suction power,

Loaded particle filter particle indicator

optical signal shows the particle filter condition,

Interface SUB D9

remote ON/OFF; filter 100%; operation status

Vacuum modules:

High performance blower and turbines with maintenance-free EC-technology.



date of issue: 08 / 2010

ULT AG · Internet: www.ult.de · e-mail: ult@ult.de

Am Göpelteich 1 · D-02708 Löbau · Telefon 00 49 (0) 35 85 / 41 28-0 · Telefax 00 49 / (0) 35 85 / 41 28-11

Technical documentation

Air extraction and filtration unit



LAS 300 MDHD TkHA9

LAS 0300.0-aa.bb.11.5006		vacuum modules			
Parameter	unit	MD.14	MD.16	HD.12	HD.13
max. air flow	m³/h	635	900	220	400
max. vacuum	Pa	3.200	3.650	22.000	12.000
nominal capacity	m³/h at Pa	250 / 2.200	250 / 3.500	120 / 12.000	200 / 7.500
	m³/h at Pa	400 / 1.700	400 / 3.200	200 / 3.500	250 / 5.000
motor nominal power	kW	0,4	1,3	1,3	1,3
nominal voltage	V	230	230	230	230
nominal current	A	2,2	10,0	11,0	11,0
frequency	Hz	50 / 60	50 / 60	50 / 60	50 / 60
protection class	IP	54	54	54	54
typ blower		EC-blower	EC-blower	EC-turbine	EC-turbine
noise level (bei 50 - 100%)	dB(A)	52 – 56	65 – 71	60 - 70	60 – 71
with sound absorber(at 50 - 100%)	dB(A)	48 - 51	62 - 65	57 - 67	59 - 68
air flow controller		incl.	incl.	incl.	incl.
loaded filter indicator		incl.	incl.	incl.	incl.
SUB D9 interface		incl.	incl.	incl.	incl.
air intake	Ø	2x Ø 75 mm; optional: further Ø			
	position	on the top or on the rear side			
air outlet		air exhaust louver; optional: exhaust air connection			
	position	on the rear side of the vacuum module			
length	mm	475			
width	mm	625			
height	mm	1002			
weight	kg	approx. 70			
length of power cable	m	3			
filter structure	HFM TkH	main filtermodule			
		filter system: storage filter			
		(1) pocket filter F9-01 ik	ULT 02.1.454		
		(2) filter mat; F5-02 fine dust filter	ULT 02.1.472		
	(3) particle filter H13	ULT 02.0.415			
	NFM A9	secondary filter module			
		filter system: storage filter			
ULT300 filter ACD base		ULT 02.1.401			
(1) gase filtration; activated charcoal filter					
additional options:					
sound absorber	(1)	changed depth: 685 mm			
exhaust air connection	(2)	1 x Ø 100 mm			
without extra module	(3)	hose connection on the rear side: 2x Ø 75mm; optional further Ø			
without extra module	(4)	hose connection on the top: 2x Ø 75mm; optional further Ø			
mounting bracket for ALSIDENT-arm	(5)	Alsident-U-Profil S50/75; for max. 2 ALSIDENT arms			



date of issue: 08 / 2010

ULT AG · Internet: www.ult.de · e-mail: ult@ult.de

Am Göpelteich 1 · D-02708 Löbau · Telefon 00 49 (0) 35 85 / 41 28-0 · Telefax 00 49 / (0) 35 85 / 41 28-11

LAS 300 MDHD TkHA9



laser smoke

Functional principle:

At the clean-air side of the filter, a vacuum generator with a high pressure reserve produces a volume flow matched to the respective application.

This volume flow can be individually and infinitely variably regulated. Thus, the polluted air will be reliably extracted.

The **particles** are separated and held back in a multi-stage saturation-type filtering system.

Main filter module TkH

ULT 300 Filter ASD-03

- (1) **pre-filter** pocket filter F9, in a disposal carton
- (2) **fine dust filter** filter mat F5
- (3) **particle filter** HEPA H13

Gaseous and vaporous air pollutants are separated (adsorbed) in an activated charcoal filter. The filtering effect of activated charcoal is based on adsorption, i. e. an accumulation of substances (to be filtered out) on the surface of the activated charcoal.

Secondary filter module A9

ULT 300 Filter ACD base

- (1) **gas filtration** activated carbon, 9 kgs

This excellent filter efficiency makes it possible to recirculate the **filtered air** and reduce energy costs.

Further additional options can be connected to the unit. These are to be selected according to the respective requirements.

For the extraction and filtration from pollutants varying from this application case, other module combinations are available.

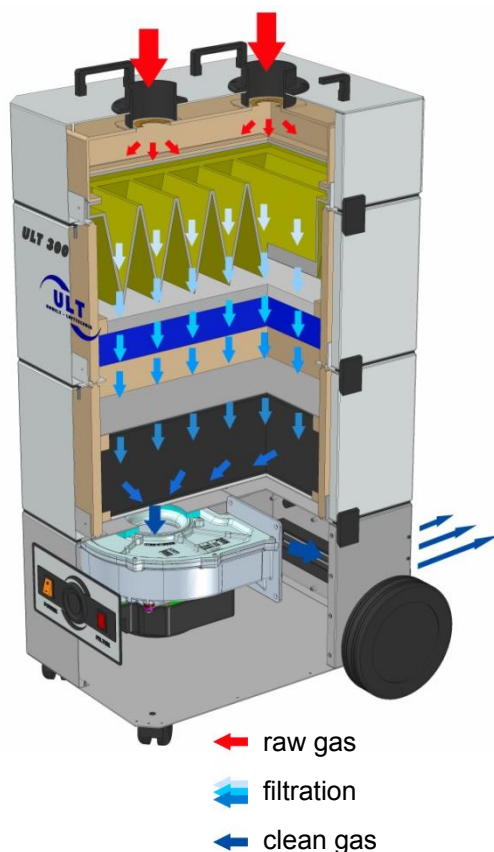

date of issue: 07 / 2010

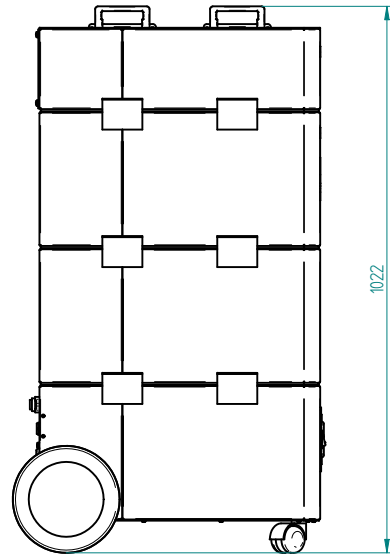
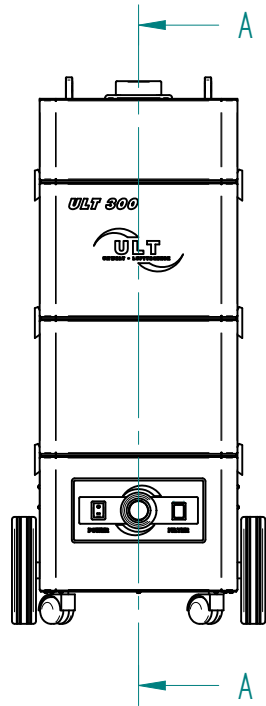

main filter module HFM017

secondary module NFM002

vacuum module

1022

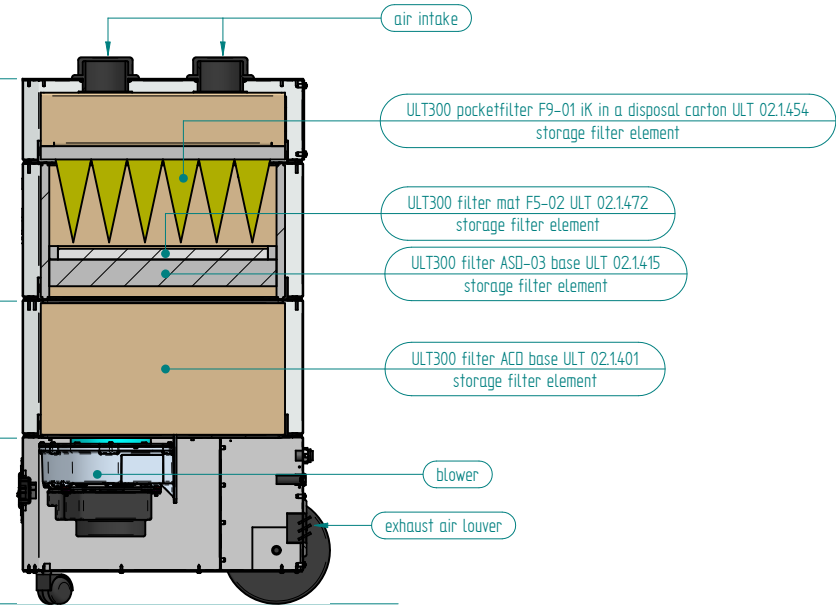

section A-A

air intake

ULT300 pocketfilter F9-01 iK in a disposal carton ULT 02.1454
storage filter element

ULT300 filter mat F5-02 ULT 02.1472
storage filter element

ULT300 filter ASD-03 base ULT 02.1415
storage filter element

ULT300 filter ACD base ULT 02.1401
storage filter element

blower

exhaust air louver

individual components

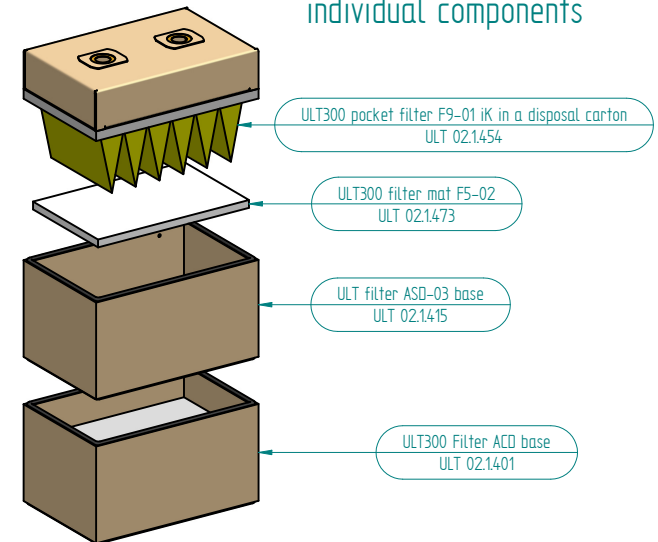

ULT300 pocket filter F9-01 iK in a disposal carton
ULT 02.1454

ULT300 filter mat F5-02
ULT 02.1473

ULT filter ASD-03 base
ULT 02.1415

ULT300 Filter ACD base
ULT 02.1401

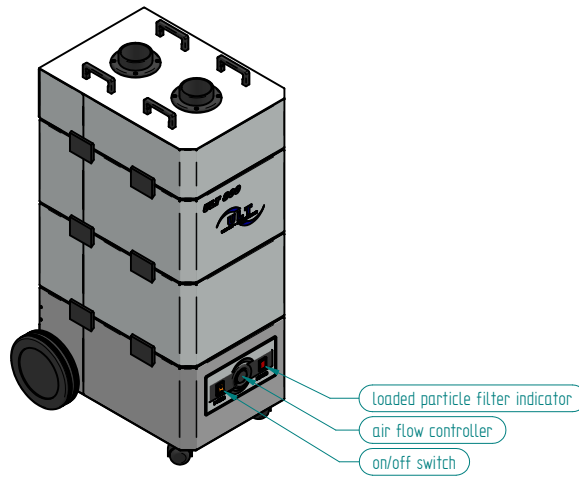
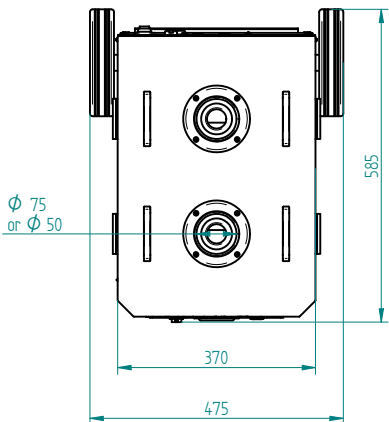

loaded particle filter indicator

air flow controller

on/off switch



				ULT AG Am Gopelteich 1 D-02708 Lobau		Benennung: ULT 300x TKHA9 Gesamtzeichnung Zeichnungsnummer:	
				2010	Datum	Name	
				Bearb.	25.05	R. Schütze	
				Ausgabe			
				Änderung	Tag	Name	
				ULT 300_00_062_101			Maßstab: 1 : 10